

## INSTRUCTION MANUAL

### EDGER MACHINE BT60H – BT60E – BT75H



Nijverheidsstraat 10, 1840 Londerzeel/Belgium  
Tel: +32 (0)52 315 350 - Tel: +32 (0)52 315 351 - Fax: +32 (0)52 315 359  
E-mail: [info@betontrowel.com](mailto:info@betontrowel.com) - [www.betontrowel.com](http://www.betontrowel.com)  
BE 0821.249.312

BNP FORTIS:

BE81 0015 9813 5624

BBRUBEBB



# BETON TROWEL BV

---

Use this guide along with the parts lists attached to locate and identify components of your trowel. When ordering replacement parts, be sure to provide the model number and serial number from the trowel.

## **Copyright**

© Copyright 2011 by Beton Trowel.

## **Contact**

BETON TROWEL  
Nijverheidsstraat 10  
1840 Londerzeel  
BELGIUM  
[www.betontrowel.com](http://www.betontrowel.com)

---

Nijverheidsstraat 10, 1840 Londerzeel/Belgium  
Tel: +32 (0)52 315 350 - Tel: +32 (0)52 315 351 - Fax: +32 (0)52 315 359  
E-mail: [info@betontrowel.com](mailto:info@betontrowel.com) - [www.betontrowel.com](http://www.betontrowel.com)  
BE 0821.249.312

BNP FORTIS:

BE81 0015 9813 5624

BBRUBEBB

## Foreword

### **Quality assurance / machine break in**

The machine is the product of extensive engineering development designed to give long life and unmatched performance. The trowels are shipped fully assembled, and only require filling with fuel and a brief check of lubricant levels in preparation for operation.

You can help ensure that your trowel will perform at top levels by observing a simple routing on first use. Consider that your new trowel is like a new car. Just as you would break in a new car to the road or any new machine to the job, you should start gradually and build up to full use. Learn what your machine can do and how it will respond. Refer to the engine manufacturer's manual for run-in times. Full throttle and control may be used after this time period, as allowed by material. This will serve to further break in the machine on your specific application, as well as provide you with additional practice using the machine.

We thank you for the confidence you have placed in us by purchasing a Beton Trowel machine and wish you many years of satisfied use.

## Table of contents

<b>Foreword</b>	<b>3</b>
<b>Operation</b>	<b>5</b>
1 Use	5
2 Safety precautions	5
3 ASSEMBLY INSTRUCTIONS	6
4 OPERATION (Floating)	6
5 OPERATION (Finishing)	7
6 STARTING PROCEDURE: *WARM CLIMATE	7
7 STARTING PROCEDURE: *COLD CLIMATE	7
8 STOPPING PROCEDURE	7
9 TRANSPORTING	7
10 Lubrication	8
11 Storage	8
<b>Maintenance</b>	<b>9</b>
1 Preventative maintenance and routine service plan	9
2 Maintenance plan	10
3 Service	11
<b>Labels</b>	<b>12</b>
<b>Specifications</b>	<b>13</b>
1 Technical data sheet	13
2 Wire Diagram	13
3 Parts	14
<b>Declaration of Conformity</b>	<b>24</b>

## Operation

### 1 Use

The trowel has been developed to float and finish the edges of concrete floors, up to perimeter walls, around columns and small areas, eliminating tiring hand troweling and increasing overall productivity and quality.

### 2 Safety precautions

- ❖ Always keep unauthorized, inexperienced, untrained people away from this machine.
- ❖ Rotating and moving parts will cause injury if contacted. Make sure guards are in place. Keep hands and feet away from moving parts.
- ❖ Fuel the machine only when the engine is stopped, using all necessary safety precautions.
- ❖ The engine must always be stopped before attempting any repair or adjustments. Ignition switch should be off.
- ❖ To avoid slipping and loss of control when starting the trowel, the operator should maintain good footing. It is recommended that the operator wear safety shoes for added protection.
- ❖ Be careful when working around pipes or ducts protruding from the floor or slab edges. If the trowel blades hit such obstacles, damage to the machine or possible operator injury may result.
- ❖ When starting the machine, do not exceed 1/3 throttle position. A higher setting may cause the centrifugal clutch to engage and the handle to rotate.
- ❖ Be careful not to come in contact with the muffler when the engine is hot, serious burns may result!
- ❖ Over time, the blades will form a sharp edge. Be careful when handling the old blades.



Never operate the machine in an explosive atmosphere, near combustible materials or where ventilation does not clear exhaust fumes. Repair fuel leaks immediately. Refer to your engine owner's manual for more safety instructions.

### 3 ASSEMBLY INSTRUCTIONS

Your new trowel has been shipped to you fully assembled. All you need to do is unfold the handle and fasten the knob. Remove any shipping or packing materials. Be sure to remove and discard the band securing the safety/stop switch to the left handle. This serves only to facilitate shipping and is not intended to be a permanent feature. When removing the machine from the carton, be careful to use the handles to lift the unit from the carton. NEVER LIFT THE MACHINE BY THE RING OR DISC. Filling the fuel tank and a brief check of lubricant levels in preparation for operation is required.



**IMPORTANT:**

Before running machine with belt installed, ensure that engine idles properly and that the safety-switch shuts off the engine.



**ATTENTION:**

For any information regarding engine adjustments, please refer to the engine manual supplied.

### 4 OPERATION (Floating)

When the slab has set sufficiently firm that the operator's footprint leaves a very slight depression on the surface of the slab, it is ready for the floating operation. Guiding the machine on the slab is very simple, a slight upward lift of the handle causes the machine to travel to the left. Holding the handle in the neutral position, will slowly cause the machine to spin in one spot. Slight downward pressure on the handle causes the machine to travel to the right. Best results are obtained by covering approximately 4" on each turn. In other words, let the machine move right or left, backwards or forwards, approximately 4" with each revolution of the trowels. To fill a hole or cut down a hump, move the unit back and forth over the problem area.

Under normal operating conditions the machine should cover as much as 1000 sq. ft. in about 15 minutes. It is recommended that a slight tension on the trowel control cable, (but *not* a definite tilt), during the floating operation will cause the machine to operate much smoother. After the floated slab has set sufficiently, it is ready for the finishing operation.



**CAUTION:**

Do not let the machine stand in one spot on the soft cement. Lift from the slab when the floating operation is complete.

## 5 OPERATION (Finishing)

When starting the finishing operation, never set the trowels up over 1/4" pitch. After the floating operation, the first thing to do is to remove the floating disc from the blades. Clean the blades, spider plate and disc from cement paste collected during the floating operation. Increase the blade pitch up to a maximum of 1 cm for the first finishing operation and then continue to increase the pitch on the following finishing operations. Continue the finishing passes until you obtain the desired floor finish. The time required between each finishing pass is again dependent on the weather conditions and water content of the concrete etc. If some areas of the concrete set/harden too fast you may apply a small amount of water using a hand brush as an aid to achieving the finish.

## 6 STARTING PROCEDURE: \*WARM CLIMATE

Open fuel valve on gas tank. Set throttle lever to "Fast" idle position, set choke to closed position, start engine. Open choke slightly to prevent flooding. Move to "Open" or "Run" position when engine is warm, increase throttle to maximum operation position (3600 rpm).

## 7 STARTING PROCEDURE: \*COLD CLIMATE

Follow same procedure as above but allow longer warm-up period – 3 to 5 minutes. In cold weather, oil is much heavier to move and requires more time to work its way into the moving parts. If maximum power is not attained, allow further warm-up time.

## 8 STOPPING PROCEDURE

- ❖ Throttle engine down.
- ❖ Turn off stop switch.

## 9 TRANSPORTING

When transporting the trowel, always keep the handle folded and the blades flat on the floor to prevent damage to the pitch control system. Always keep the floating disc underneath the blades to protect them against damage.



### CAUTION:

Never lift the trowel by the rotating ring; use the hoist hook or handle provided on the trowel. Remove the float disc when lifting machine more than 100cm (40in). The floating disc could fall off.

## 10 Lubrication

- ❖ **ENGINE OIL:** The long life and successful operation of any piece of machinery is dependent on frequent and thorough lubrication. Before using the trowel, always check your engine for oil. Use proper engine oil as recommended in the engine manufacturer's manual. Fill crankcase to levels as recommended.
- ❖ **SPIDER PLATE :** The trowel arm on the spider plate does not require lubrication. If a trowel arm becomes jammed, this is probably due to a bent arm, which will require replacement. Appropriate "winterize" steps should be taken if the machine is going to be stored for long periods of time.
- ❖ **GEARBOX:** In operation the gearbox lubricant is in a fluid state. When the machine is stopped the lubricant returns to a gel state. It will only be necessary to inspect the sealed components if the outside of the gearbox gets too oily or otherwise shows evidence of a leak. If this happens, clean the machine thoroughly and look for leaks. Effect necessary repairs immediately. Use SHELL TIVELA COMPOUNDS 'A' (0.3L, 10.1oz.) gear oil or equivalent to top up the gear box after any maintenance to the internal components.

## 11 Storage

The following steps should be taken to prepare your trowel for extended storage.

- ❖ Close fuel shut off valve.
- ❖ Siphon excess gasoline from tank.
- ❖ Start engine until it stops from lack of fuel. This will use up all the fuel in the carburetor and prevent formation of deposits due to evaporation of fuel.
- ❖ Remove spark plug and pour 2 oz. of SAE-30 or SAE-40 motor oil into the cylinder. Slowly crank the engine 2 or 3 times to distribute the oil throughout the cylinder. This will help prevent rust during storage. Replace spark plug.
- ❖ Store the unit in an upright position in a cool, dry, well ventilated area.

## Maintenance

### 1 Preventative maintenance and routine service plan.

This trowel has been assembled with care and will provide years of service. Preventative maintenance and routine service are essential to the long life of your trowel. Your dealer is interested in your new machine and has the desire to help you get the most value from it. After reading through this manual thoroughly, you will find that you can do some of the regular maintenance yourself. However, when in need of parts or major service, be sure to see Beton Trowel.

- ❖ **AIR CLEANER** - Keep air filter clean at all times. Wash away dust and debris using a non-oil based cleaning solvent. Let the filter dry before re-installing.
- ❖ **LUBRICATION** – Always check engine oil regularly. Use proper engine oil as recommended. See chart on this page. Fill crankcase to levels as recommended in manufacture's engine manual.
- ❖ **SPARK PLUG** – Check and clean spark plugs regularly. A fouled, dirty or carboned spark plug causes hard starting and poor engine performance. Set spark plug gap to recommended clearance. Refer to engine manual.
- ❖ **BELT TENSION – IMPORTANT!**

When the engine is switched off, and the machine has stopped, the normal belt play should be loose. This is due to the clutch type. When the machine is running at full throttle, the clutch will close in, which tightens the belt causing the gearbox to engage. When adjusting the belt make sure that the clutch is in alignment with the follower pulley. Secure belt guard. Tighten all engine mount bolts, and tighten lock nuts.

## 2 Maintenance plan

Routine Service Intervals		Each use	After 1.5 months or 50 hrs	Each 3 months or 100 hrs	Each 6 months or 200 hrs	Each 9 months or 300 hrs	Each 12 months or 400 hrs
<b>General Inspection:</b>							
Guards	Check		o	o	o	o	o
Warning stickers	Check		o	o	o	o	o
Test run	Check operation		o	o	o	o	o
<b>Controls:</b>							
Dead-man switch operation	Check	o	o	o	o	o	o
Pitch control assembly	Check	o	o	o	o	o	o
	Lubricate		o	o	o	o	o
<b>Engine:</b>							
Engine oil	Check Level	o	o	o	o	o	o
	Change		o		o		o
Engine oil filter	Replace				o		o
Oil cooler	Clean			o	o	o	o
Cooling Fins	Clean		o	o	o	o	o
Air cleaner	Check - clean	o	o	o	o	o	o
	Replace						o
Air Intake Line	Check				o		
	Replace						2 yrs
Fan Belt	Check tightness				o		o
	Replace						500 hrs
Valve clearance	Check-adjust				o		o
Fuel filter	Check & Clean			o	o	o	o
	Replace				o		o
Fuel Tank	Clean						500 hrs
Engine wiring	Check						o
<b>Drive Train:</b>							
Clutch / Pulley operation	Check	o	o	o	o	o	o
Spider plate assembly	Check	o	o	o	o	o	o
	Lubricate				o		o
V-Belt	Check	o	o	o	o	o	o
Blades	Check	o	o	o	o	o	o
<b>Gearbox:</b>							
Gearbox oil	Check Level				o		o
	Change	o			o		o
Gearbox breathers	Check operation			o	o	o	o

### 3 Service

Due to the nature and environment of use, the machines could be exposed to severe operating conditions. Some general maintenance guidelines will extend the useful life of your trowel.

- ❖ The initial service for your trowel should be performed after 25 hours of use, at which time your mechanic (or authorized repair shop) should complete all of the recommended checks in the schedule above.
- ❖ Regular service according to the schedule above will prolong the life of the trowel and prevent expensive repairs.
- ❖ Keeping your trowel clean and free from debris is the single most important regular maintenance operation, over and above the checks in the service schedule above, that can be performed. After each use your trowel should be cleaned to remove any dust and debris from the undercarriage and surrounding components. Use of a power washer will make clean up quick and easy, especially if a non-stick coating was applied prior to use.
- ❖ In the Service Schedule above, items that should be checked, replaced or adjusted are indicated by “o” in the appropriate column. Not all trowel models include the same features and options and as such not all service operations may have to be performed. For ease of recording place a checkmark (√) through the “o” when the item is complete. If an item is not required or not completed place an “x” through the “o” in the box.

## Labels

SAFETY PRECAUTIONS	
	<p><b>! DANGER</b></p> <p><b>EXPLOSION HAZARD</b> Never operate the machine in an explosive atmosphere, near combustible materials or where ventilation does not clear exhaust fumes.</p>
	<p><b>WARNING</b></p> <p><b>BURN HAZARD</b> Never come into contact with the engine or muffler when engine is operating or shortly after it is turned off. Serious burns may occur.</p>
	<p><b>! CAUTION</b></p> <p><b>ROTATING HAZARD</b> Never place hands or feet inside safety guard rings. Serious injury will result from contact with rotating blades.</p>
	<p><b>! CAUTION</b></p> <p><b>MOVING PARTS</b> Before starting the machine ensure that all guards and safety devices are in place and functioning properly.</p>
	<p><b>! ATTENTION</b></p> <p><b>READ OWNERS MANUAL</b> Read and understand operator's manual before using this machine. Failure to follow operating instructions could result in serious injury or death.</p>

## Specifications

### 1 Technical data sheet

MODEL	BT60H	BT60E	BT75H
OPERATING DIAMETER	60 CM (24")	60 CM (24")	75 CM (30")
ENGINE OPTIONS	HONDA GX160 5.5HP	ELECTRIC 230V 1.5 kW VARIABLE SPEED	HONDA GX160 5.5HP
HANDLE TYPE	FOLDING	FOLDING	RIGID TRI-TUBE DUAL
HANDLE VIBRATION	1.1 – 1.5 M/S	1.1 – 1.5 M/S	1.1 – 1.5 M/S
SOUND	97 – 103 LWA (dB) 82 -86 LPA (Db)	97 – 100 LWA (dB) 82 -84 LPA (Db)	97 – 103 LWA (dB) 82 -86 LPA (Db)
WEIGHT	53 KG	55 KG	72 KG

### 2 Wire Diagram

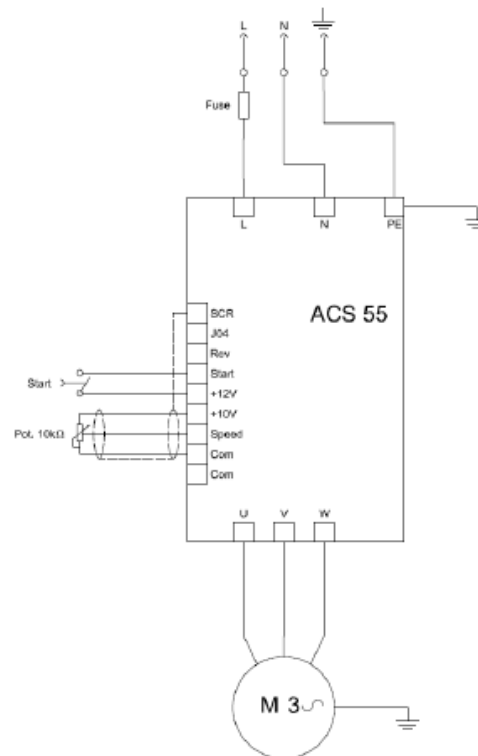

## 3 Parts

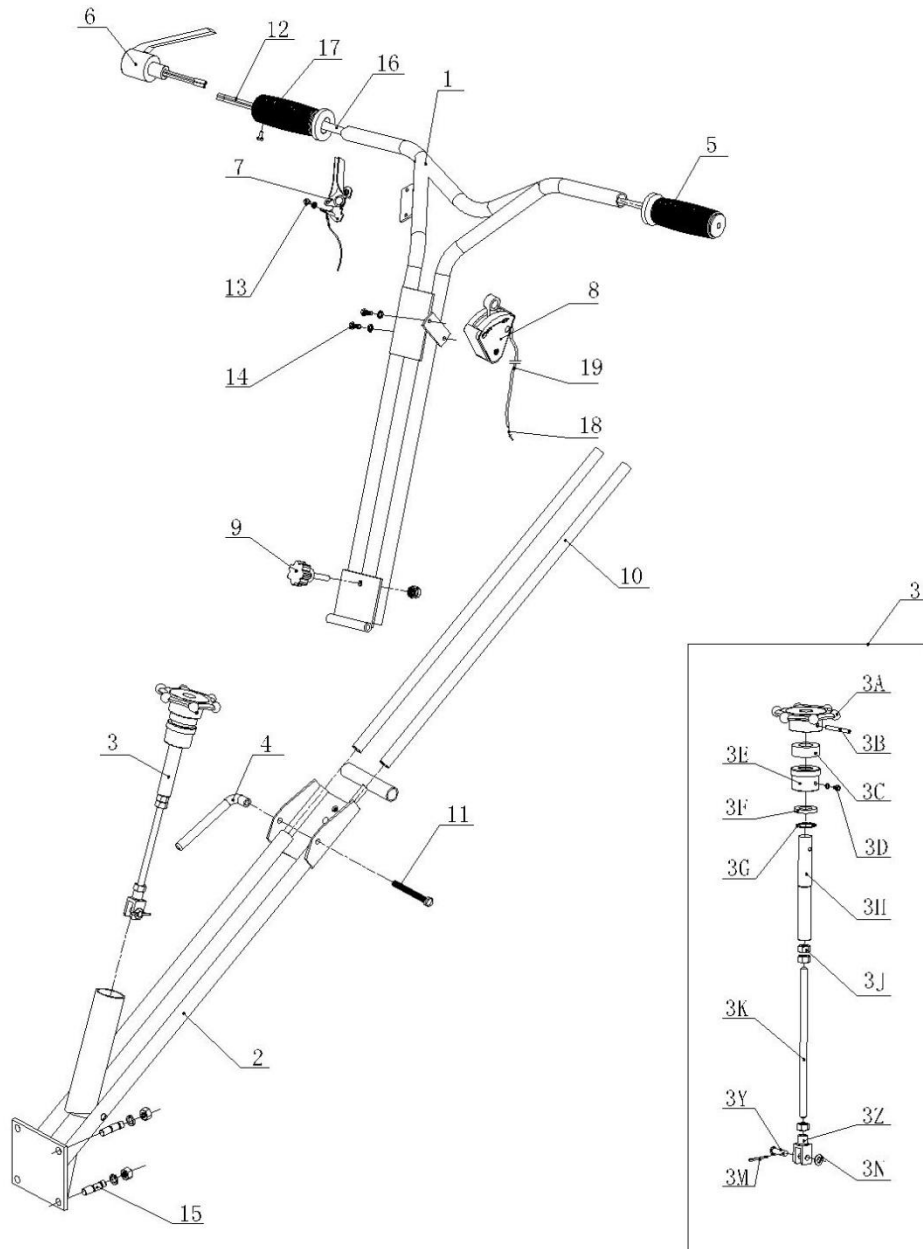

Nijverheidsstraat 10, 1840 Londerzeel/Belgium  
 Tel: +32 (0)52 315 350 - Tel: +32 (0)52 315 351 - Fax: +32 (0)52 315 359  
 E-mail: info@betontrowel.com - www.betontrowel.com  
 BE 0821.249.312

BNP FORTIS:

BE81 0015 9813 5624

BBRUBEBB

Item No.	Part No.	Description	Qty.
1	1165100B	UPPER HANDLE WELDING PART	1
2	1165300A	LOWER HANDLE WELDING PART	1
3	1165500A	KNOB ASSY	1
3A	1165006	KNOB	1
3B	9024	PIN	1
3C	9089	BEARING	1
3D	9093	BOLT	1
	9022	SPRING WASHER	1
3E	1165007	BUSHING	1
3F	1165008	WASHER	1
3G	9124	RETAINER	1
3H	1165009	ALUMINIUM BUSHING	1
3J	9091	NUT	3
3K	1165010	THREADED SHAFT	1
3M	9094	PIN	1
3N	9038	WASHER	1
3Y	9090	PIN	1
3Z	1165011	CONNECTOR	1
4	1165005	LOCKING LEVER	1
5	9035	GRIP	1
6	1165200A	DEADMAN SWITCH	1
7	4365400	THROTTLE CONTROL	1
8	4365200	SAFETY SWITCH	1
9	9121	LOCKING KNOB	1
	9236	NUT	1
10	9083	PLASTIC TUBE	2
11	9087	BOLT	1
12	1165200DX1	WIRE	2
13	9021	SCREW	3
	9011	WASHER	2
	9128	SPRING WASHER	1
14	9010	SCREW	2
	9011	WASHER	2

Item No.	Part No.	Description	Qty.
15	1164002	BOLT	4
	9046	SPRING WASHER	4
	9091	NUT	4
16	9126	SLEEVE	1
17	9035a	GRIP	1
18	9009	WIRE	1
	9007	CONNECTOR	1
	9012	CONNECTOR	1
19	9008	SLEEVE	1

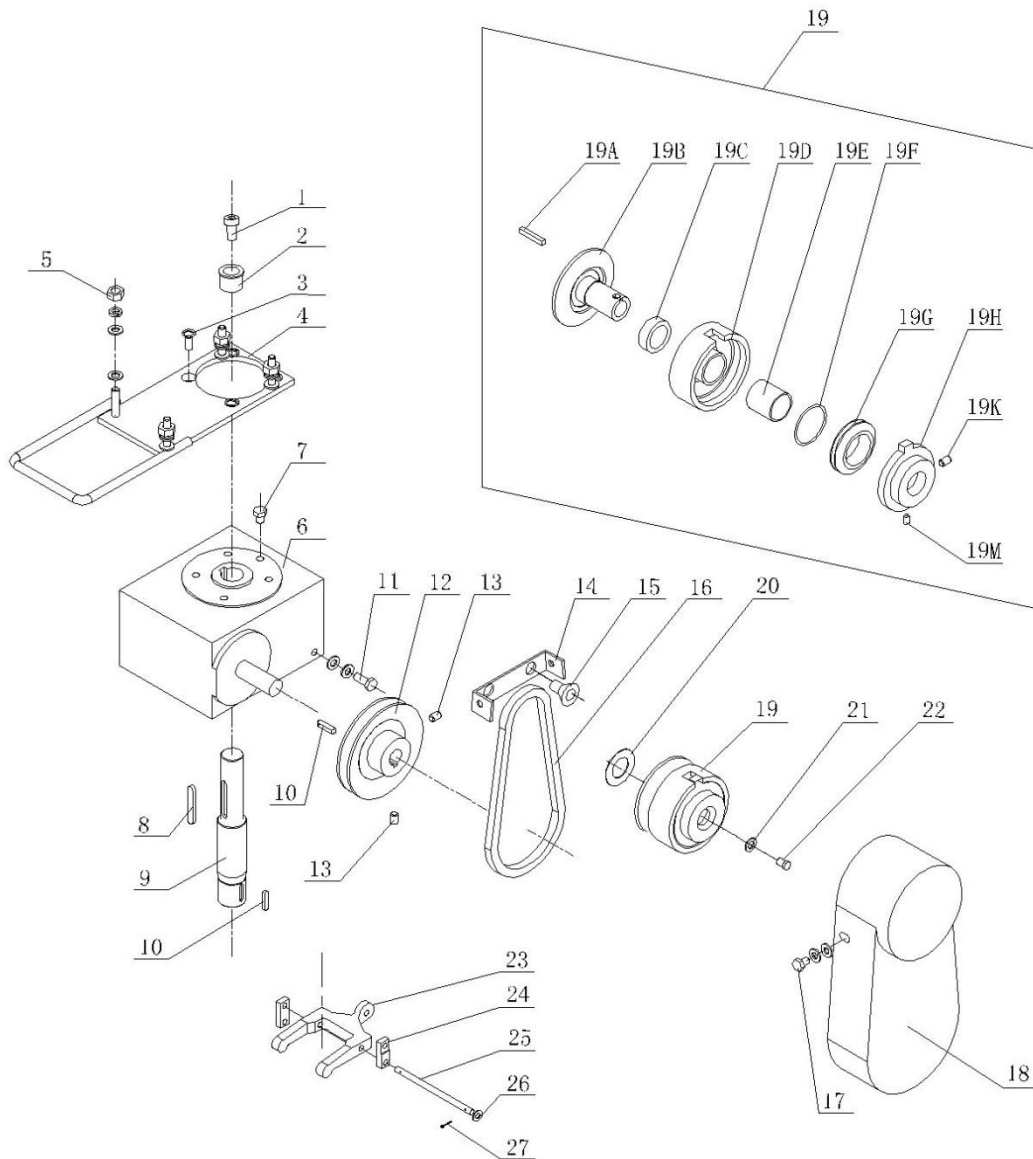

Nijverheidsstraat 10, 1840 Londerzeel/Belgium  
 Tel: +32 (0)52 315 350 - Tel: +32 (0)52 315 351 - Fax: +32 (0)52 315 359  
 E-mail: info@betontrowel.com - www.betontrowel.com  
 BE 0821.249.312

BNP FORTIS:

BE81 0015 9813 5624

BBRUBEBB

Item No.	Part No.	Description	Qty.
1	9410	BOLT	1
2	1166008	BUSHING	1
3	9088	SCREW	4
4	1164100	ENGINE DECK	1
5	9036	NUT	4
	9038	WASHER	8
	9037	SPRING WASHER	4
6	1164001	GEARBOX	1
7	4364100A	RELEASE VALVE	1
8	9109	KEY	1
9	1164006	MAIN SHAFT	1
10	9100	KEY	2
11	9098	BOLT	2
	9038	WASHER	2
	9037	SPRING WASHER	2
12	1162003	PULLEY	1
13	9101	SCREW	2
14	1162001	MOUNTING PLATE	1
15	9079	SCREW	2
16	9102	BELT	1
17	9097	BOLT	2
	9037	SPRING WASHER	2
	9038	WASHER	2
18	1162002	BELT GUARD	1
19	4363000	CLUTCH	1
19A	9076	KEY	1
19B	4363001	SPINDLE	1
19C	9075	BEARING	1
19D	4363002	DRUM	1
19E	4363006	BUSHING	1
19F	9077	SPRING	1
19G	4363004	WEIGHT	1
19H	4363003	FACE PLATE	1
19M	9078	SCREW	1
19K	9293	SCREW	1
20	1163001	WASHER	1

Item No.	Part No.	Description	Qty.
21	1163002	WASHER	1
22	9096	SCREW M8	1
23	1165012	YOKE ARM	1
24	1164003	CONNECTOR	2
25	1165013	SHAFT	1
26	9038	WASHER	2
27	9094	PIN	2

## New Gear Box Configuration (assy code 4244000) :

- Completely interchangeable with old gearbox (assy code 1164100)
- Starting from S/N 2108001

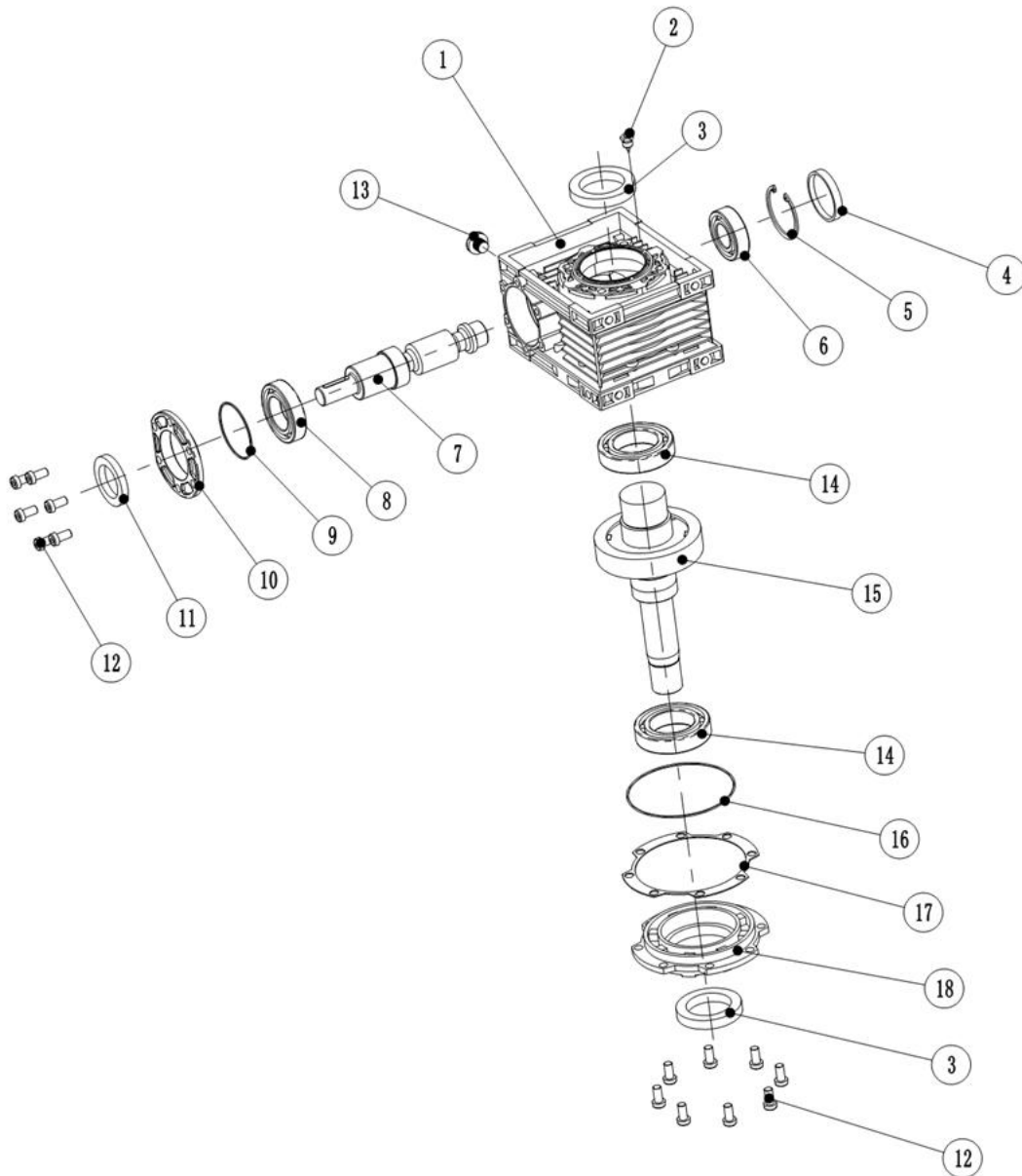

Nijverheidsstraat 10, 1840 Londerzeel/Belgium  
 Tel: +32 (0)52 315 350 - Tel: +32 (0)52 315 351 - Fax: +32 (0)52 315 359  
 E-mail: info@betontrowel.com - www.betontrowel.com  
 BE 0821.249.312

BNP FORTIS:

BE81 0015 9813 5624

BBRUBEBB

Item No.	Part No.	Description	Qty.
1	4244001Z	GEARBOX CASING	1
2	4364100A	RELEASE VALVE	1
3	10070	SEAL	2
4	10063	COVER	1
5	10064	RETAINER	1
6	10065	BEARING	1
7	4244009Z	COUNTER SHAFT	1
8	10066	BEARING	1
9	10067	SEAL	1
10	4244010Z	COVER	1
11	10068	SEAL	1
12	10071	BOLT	14
13	10073	PLUG	1
14	10069	BEARING	2
15	4244008Z	MAIN SHAFT	1
16	10072	SEAL	1
17	4244006Z	PLASTIC SHIMMING	1
18	4244005Z	COVER	1

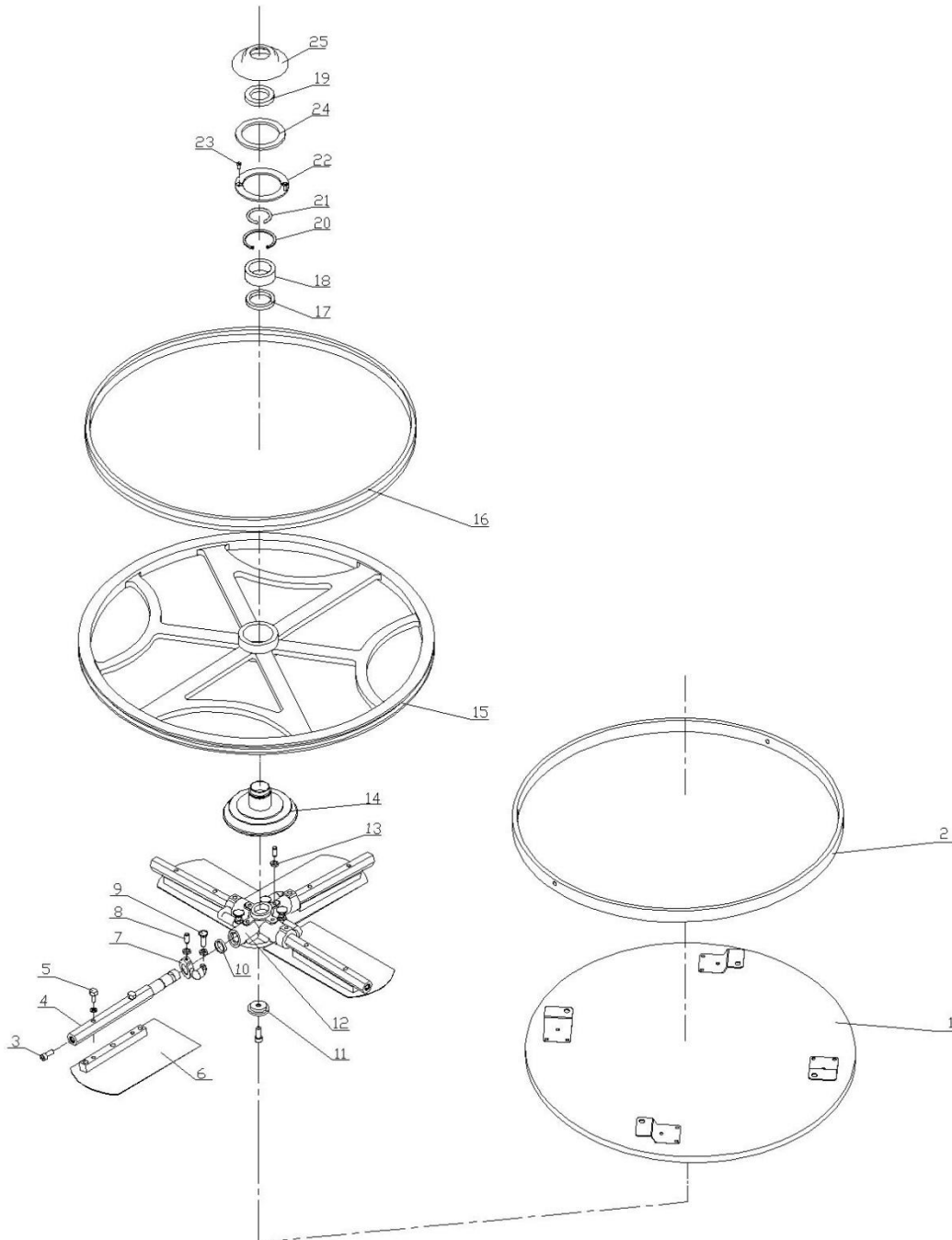

Nijverheidsstraat 10, 1840 Londerzeel/Belgium  
 Tel: +32 (0)52 315 350 - Tel: +32 (0)52 315 351 - Fax: +32 (0)52 315 359  
 E-mail: [info@betontrowel.com](mailto:info@betontrowel.com) - [www.betontrowel.com](http://www.betontrowel.com)  
 BE 0821.249.312

BNP FORTIS:

BE81 0015 9813 5624

BBRUBEBB

Item No.	Part No.	Description	Qty.
1	FP604	PAN	1
2	1166004	STABILIZER RING 60 CM	1
	1176004	STABILIZER RING 75 CM	1
3	9118	BOLT	4
4	1166003	TROWEL ARM 60 cm	4
	1176003	TROWEL ARM 75 cm	4
5	9902	BOLT	8
	9022	SPRING WASHER	8
	9330	WASHER	8
6	F60412	BLADE	4
7	1161002	LIFTING LEVER	4
8	9114	SCREW	4
	9112	NUT	4
9	9115	BOLT	4
	9112	NUT	4
10	9116	SEAL	4
11	1166009	WASHER	1
12	1166001	SPIDER PLATE	1
13	9113	SCREW	4
	9112	NUT	4
14	1166007	PRESSURE PLATE	1
15	1167001J	ALUMINUM RING 60 cm	1
	1177001J	ALUMINUM RING 75 cm	1
16	1167002	T BELT 60cm	1
	1177002	T BELT 75 cm	1
17	9111	BEARING	1
18	9110	BEARING	1
19	9106	BEARING	1
20	9108	CIRCLIP	1
21	9107	REATINER	1
22	1166006	WASHER	1
23	9105	SCREW	2
24	9120	WASHER	1
25	1166005	PRESSURE PLATE COVER	1
	1166000A	SPIDER ASSY COMPLETE 60 cm	1
	1176000A	SPIDER ASSY COMPLETE 75 cm	1

## Declaration of Conformity / Certificat de conformite / Gelijkvormigheidscertificaat / Declaracion de Conformidad / Declaracao de Concornidade / Dichiarazione Di Conformita

Model : BT60H – BT60E – BT75H

### We Beton Trowel NV

Declare under our sole responsibility that the product to which this declaration relates is in conformity with the following standards or other normative documents.

Déclarons sous notre responsabilité que le produit cette déclaration est conforme aux normes suivantes ou d'autres documents habituels.

Verklaren onder onze verantwoordelijkheid dat het product naar welke de verklaring verwijst conform de volgende standards of anders gebruikelijke documenten is.

Declaramos bajo nuestra unica responsabilidad que el producto en lo que esta declaracion concierne, es conforme con la siguiente normative u otros documentos.

Declara sob sua responsabilidade que o produto a quem esta declaracao interessar, esta em conformidade com os seguintes documentos legais ou normas directivas.

Dichiariamo sotto la ns. Unica responsibilita che il prodotto al quale questa dichiarazione si riferisce, e fabbricato in conformita ai seguenti standard e documenti di normative.

**EN 349:2008:A1:2008    EN 12100:2010    EN12649:2008+A1:2011    EN ISO 5349-2:2001 +A1:2015**

Following the provisions of Directives:

Suivant les directives determinees:

Volgens de vastgestelde richtlijnen:

Siguiendo las directivas:

No seguimento das clausulas da Directivas

Seguendo quanto indicato dalla Direttivas:

**2006/42/EC Machinery Directive**

**2000/14/EC Noise Directive**

**2001/95/EC General Product Safety Directive**

**2002/95/EC Reduction of Hazardous Waste Directive**

**LVD2014/35/EU Low Voltage Directive**

**2004/30/EU Electromagnetic Compatibility**



**Responsible Technical File : Chris Livingston for**

**Beton Trowel NV**

**Nijverheidsstraat 10**

**B-1840 Londerzeel**

**Belgium**

Tel 0032 52315350

Fax0032 52315359

25<sup>th</sup> August 2021